

Problems with Printers

This section discusses steps to diagnose and treat some of the more common problems that might occur with the MICR (food instrument and CVV) printers and report (summary sheet) printers. If problems occur which are not listed here and which cannot be resolved locally, call the NSB Helpdesk.

Below is a simplified diagram of the basic concept of printing food instruments, CVVs and reports through the internet. Every agency is uniquely set up for access to the state mainframe and for printing, based upon the design of the local network, the operating systems and sharing configuration on the local PCs, and the specific internet access setup. It is not necessary to completely understand the technical details regarding networks, Windows, or ISPs (Internet Service Providers), in order to troubleshoot printing problems.

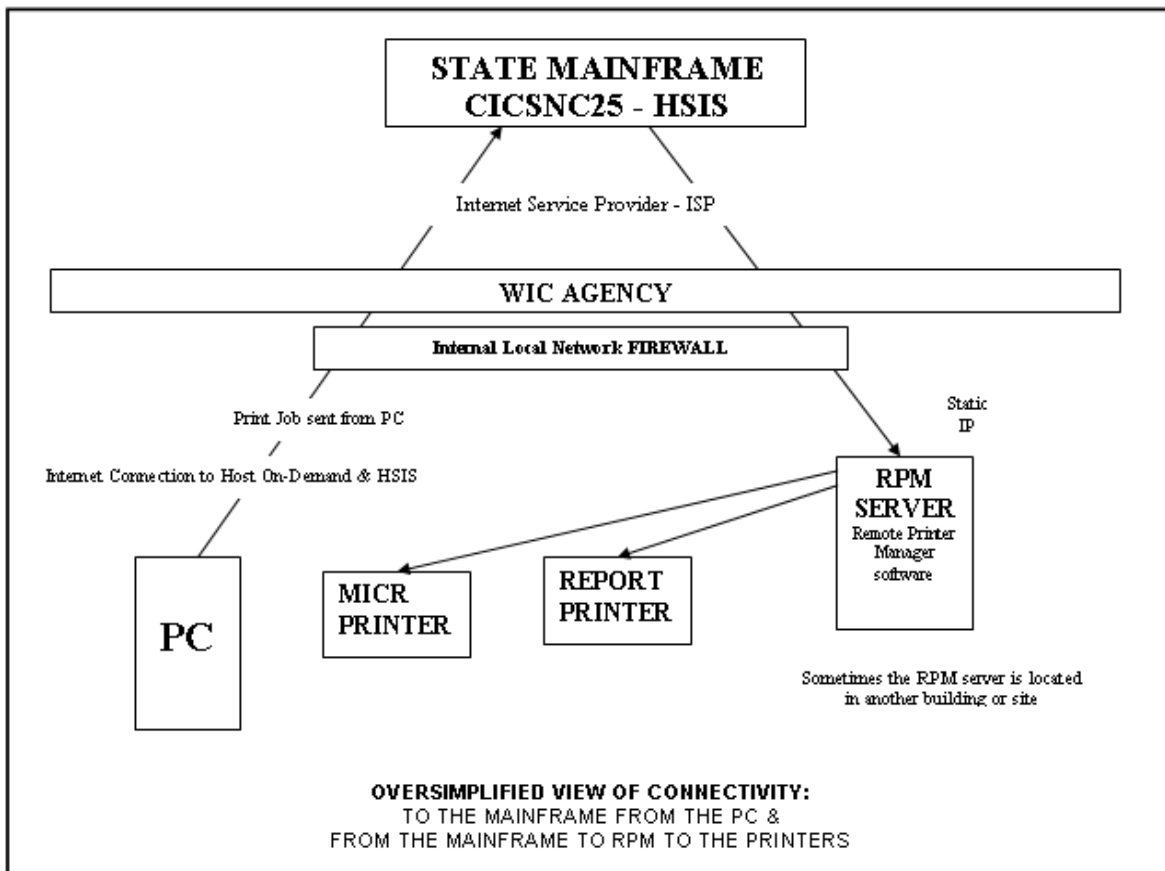

The Printer Was Formerly Printing, but Stopped Printing Recently

Determine whether the problem concerns just the one printer or all printers in the agency.

- If all of the printers are not printing, a local network issue may be responsible.
- The majority of printer issues are usually not statewide issues.

- If the user sent a print job to the printer but nothing prints out, and there are no error messages
 - ▶ Reset the printer by turning the printer off and waiting about 10 seconds.
 - ▶ Turn the printer back on.

- If the printer does not start printing
 - ▶ During normal business hours, contact the NSB Helpdesk.
 - ▶ After normal business hours, contact the ITS (Information Technology Services) Helpdesk to have the printer node(s) reset.
 - ▶ Provide the eight (8) character printer node name(s) for all printers not printing (Ex. NAAP044E, NAAP355E, NAAP8001)
 - ▶ Inform the particular Helpdesk whether just the one printer or all printers are affected.
 - ▶ Note whether or not this printer has printed satisfactorily up to this time.
 - ▶ When speaking to the ITS Helpdesk, ask them to “reset and reacquire the printer node in production region CICSNC25.”

- After the printer has been reset and reacquired, if it still does not print
 - ▶ Reset the printer one more time.
 - ▶ Turn the printer off and wait about 10 seconds.
 - ▶ Turn the printer back on.

- If ITS tried to reset/reacquire the printer but got an error message such as “Waiting to connect”, proceed to the instructions below to reset the Remote Print Manager (RPM) software.

- If ITS reported an error they were not able to correct, such as a TCP/IP or Edrain error, contact the local agency IT support for assistance.

- If the printer is attached directly to a PC
 - ▶ Exit properly out of all open applications (File, Exit or File, Close)
 - ▶ Restart the PC.
 - ▶ If necessary, follow the instructions for restarting the PC in Chapter 5, Section 2, Problems with the PC or Physical Keyboard.

- If the printer isn’t printing after ITS resets the printer node, the printer was physically reset, and the PC was restarted
 - ▶ Locate the RPM server.
 - ▶ Reset the RPM software or restart the RPM server.
 - ▶ If the local agency does not use RPM, contact local IT support for further assistance.

Resetting the RPM Software

RPM Elite LPD Print Server version 4.5 is the Remote Print Manager software created by

Brooks Internet Software Company (www.brooksnet.com). This software and version has been approved by the state to manage (coordinate) print jobs sent via the internet to a number of MICR and report printers in the local agency.

Note to Local IT Support

The NSB Helpdesk does not support RPM Select LPD Print Server version 5.0 due to printing security issues. Please contact the NSB Helpdesk if RPM version 5.0 has been installed in the local agency.

Depending upon the local setup, RPM might be located on a user's PC, on a server in a special locked room, or at a main office in another site in another city.

- If the user does not know where RPM is, or does not have access to it, contact Local IT support for assistance.
- If the user knows where RPM is, and has access to the software:
 - ▶ Click on the Start menu located at the bottom left corner of the screen
 - ▶ Click on Programs
 - ▶ Click on RPM Select
 - ▶ Click on the RPM application icon

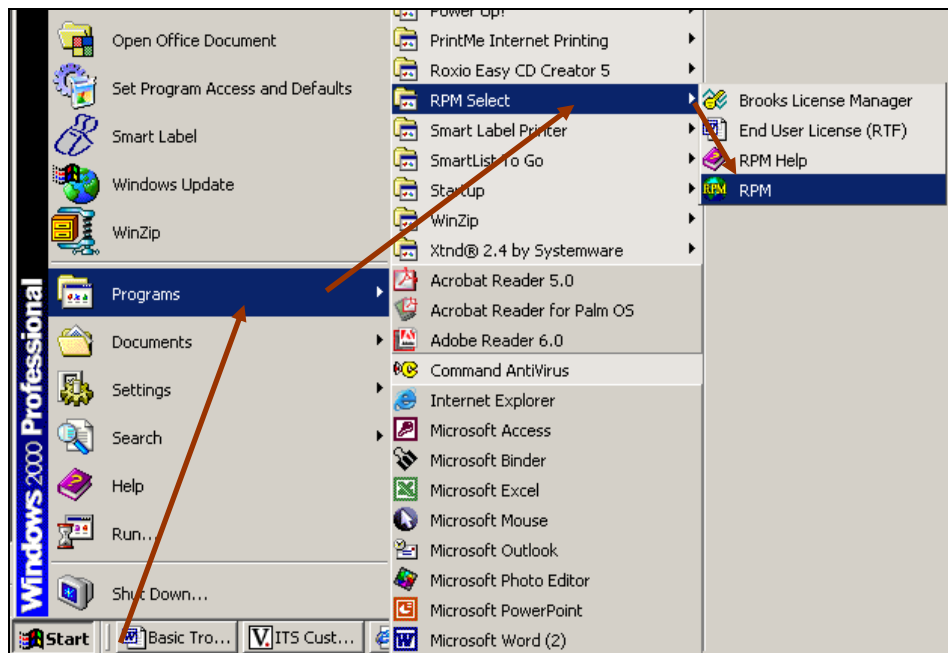

RPM Licensing Issues

- If a DEMO version of the RPM software has been installed in the WIC agency, all printing will come to a **STOP** when the license for that demo version expires.

- ▶ It is the local agency's responsibility to purchase a legitimate licensed copy of the RPM software so that the printers can continue to print through RPM.
- ▶ Either the WIC Director or the Local IT Support should handle this purchase for the local agency.
- If the RPM software is moved from one PC to another PC, the software may become locked and may need to be unlocked.
 - ▶ All printing will come to a **STOP** until the software is unlocked.
 - ▶ In order to be unlocked, the RPM Support User Maintenance (SUM) license renewal must be up to date.
- If the RPM Support User Maintenance license has expired, RPM should continue to function as normal (unless locked), but the renewal fee must be paid by the local WIC agency before Brooks Internet will provide any technical support.
 - ▶ If the NSB Helpdesk and/or the Local IT support cannot resolve a difficult technical issue, or the RPM software has become locked, it is beneficial to the WIC agency to keep up with the yearly support renewal.

To take care of any RPM licensing issues:

- Contact Brooks Internet Software support at 1-800-523-9175 (M-F Pacific Time)
- Provide the RPM license (serial) number.

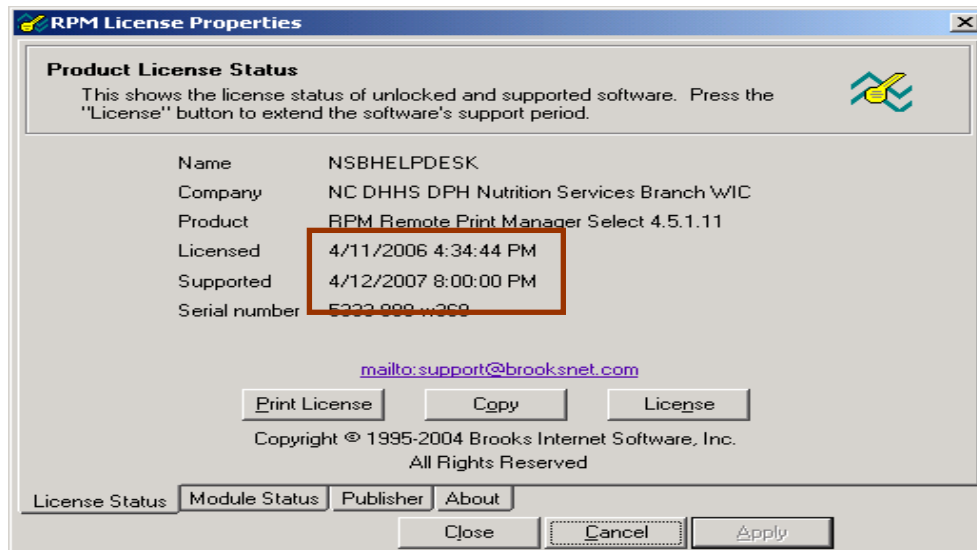

RPM Queue Enabled, Suspended or Held

If there are no licensing issues:

- Highlight the queue in RPM to determine if the printer is enabled, suspended, or held.

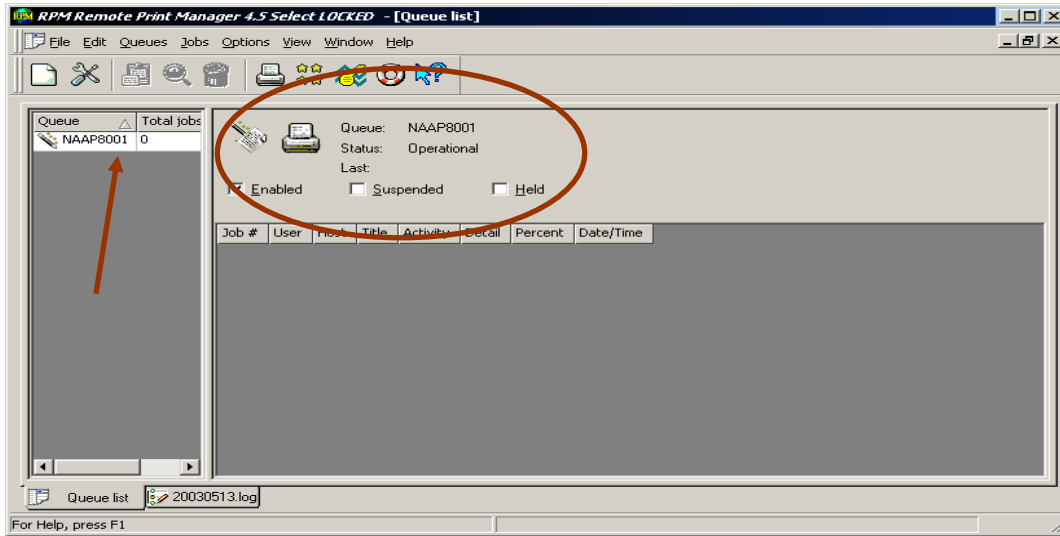

- The printer should be enabled and not suspended or held.
- If the printer is enabled, but still not printing, restart the RPM server.
- Exit out of all open applications and restart the PC on which RPM resides.
- If the printer doesn't print after resetting RPM, contact the local IT support for assistance.

If the printer queue is suspended

- Click on enabled.
- If the printer queue returns to suspended, it can sometimes mean there is a problem with the Windows configuration.
- Contact your local IT support or Brooks Internet Software for assistance.

Note to Local IT Support

If nothing seems to work after all troubleshooting has been done,
delete and recreate the problematic printer queues in RPM.
This could resolve the problem.

If the printer queue is held:

- Print jobs will be in the queue list with an activity status of hold.
- To release these jobs, you have to uncheck the held queue box from each job.

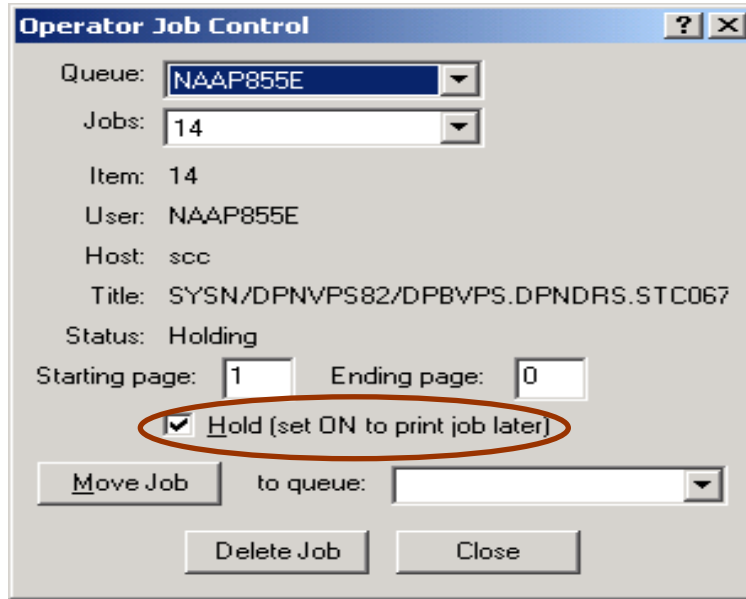

- Right click on each job with a hold status in the queue list.
- Uncheck the box: Hold (set ON to print job later).
- Click close.
- The print jobs should leave the queue list.

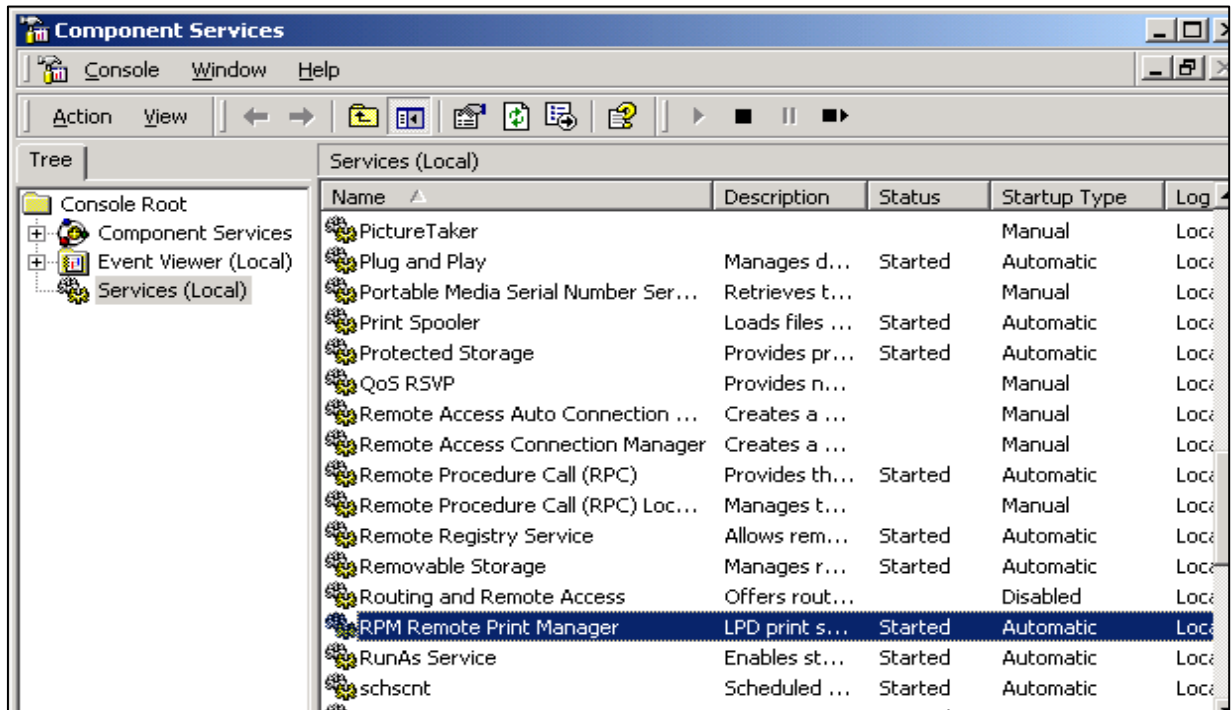

If jobs are not showing up in RPM and the network is ok:

- Select the Control Panel.
- Select Administrative Tools.

- Select Component Services.
- RPM Remote Print Manager status should be started.
- To start Services, right-click the RPM Service and click start.
- If unable to do this, restart the RPM server.

The Summary Sheet (Report) Printer Displays Error Messages

If the report printer is reporting an error message

- Reset the printer by turning the printer off, waiting a few minutes, then turning it back on.
- If the error messages remain, contact local IT support for assistance.

The MICR Printer Displays Error Messages

Consult the MICR printer user guide for any questions about the MICR printer.

- Refer to the MICR printer user guide for more information about any messages on the MICR printer that are not clear.
- Contact the NSB Helpdesk or the local IT support for further assistance.

Paper Tray Errors

If the MICR printer displays a Paper Tray error:

- Turn off the printer.
- Take the paper tray out of the printer.
- Remove the MICR check stock from the paper tray.
- Turn the tray over and make sure the green lever on the bottom of the tray is positioned between the putty colored notches (see snapshot below). If not, move the green lever into correct position:

Example 1: The green lever is NOT in correct position since it is outside of the guide notches:

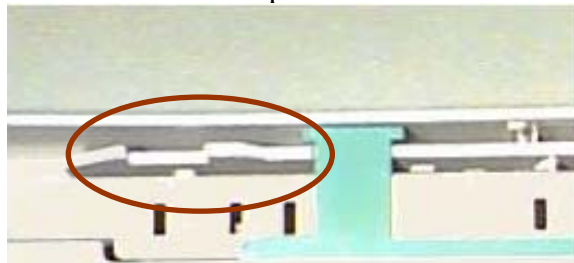

Example 2: The green lever IS in the correct position between the putty colored guide's notches:

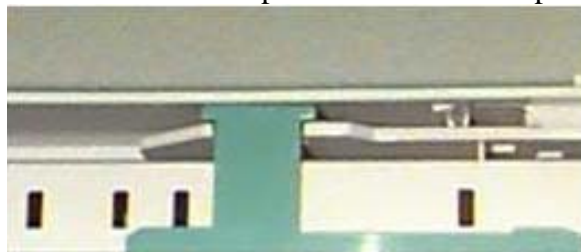

Chapter 5: TROUBLESHOOTING
Section 9: PROBLEMS WITH PRINTERS

- If the bottom of the tray is ok or has been adjusted, turn the tray to the side where the left side of the tray is facing you (see photo below).
 - ▶ There are 3 square holes on the side.
 - ▶ The first hole near the top should be completely pushed in
 - ▶ If the paper guide has been adjusted correctly, the two notches on the bottom should be sticking out.
 - ▶ Verify that the 2 bottom notches on the side are the only ones sticking out.

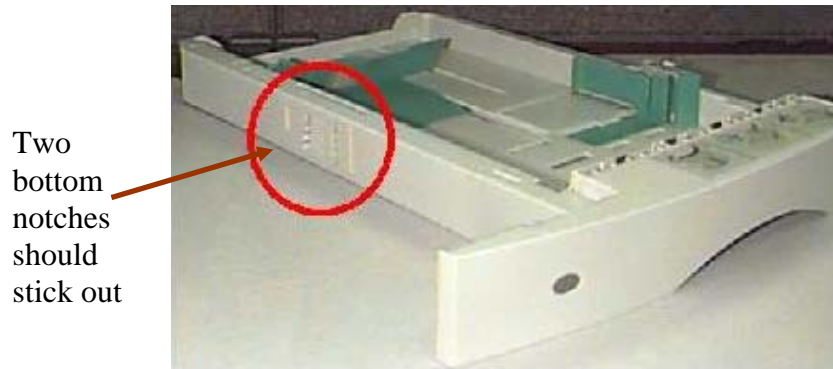

- ▶ Look inside the tray and verify that the green paper guide arrow is pointing to the LTR (letter size paper) indicator.
- ▶ Just to make sure it is in its proper place, move the tray guide back a notch or two, and then slide the green arrow back to the LTR indicator.

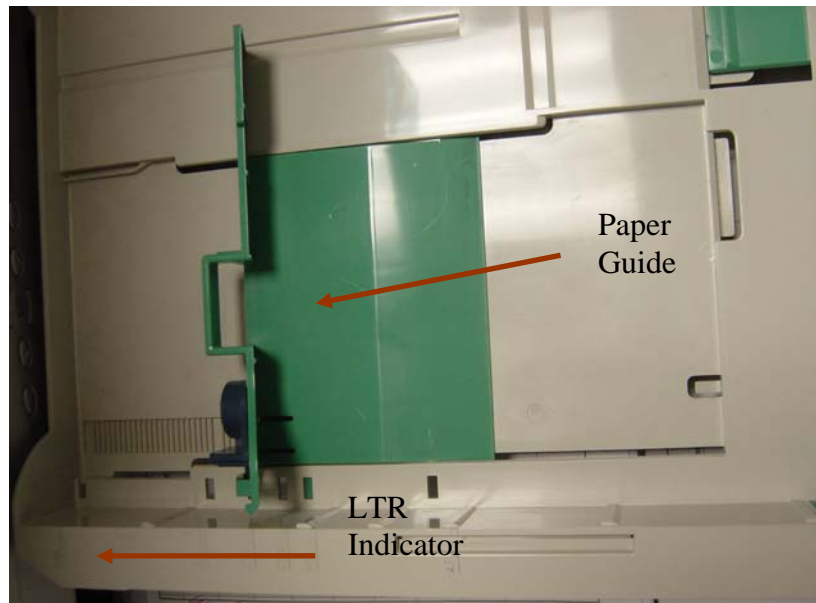

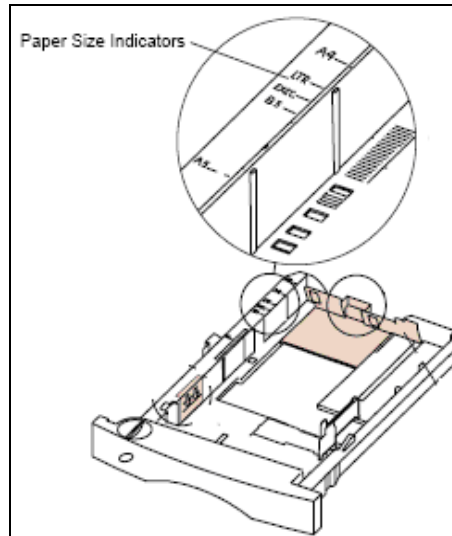

The Paper Sensor

- Once the notches on the tray are verified and the paper guide has been adjusted, look inside the printer where the tray is supposed to go.
- On the left hand side of the printer notice four silver metal parts near the back.
- These metal parts belong to the paper sensor.
- This is where the notches on the tray fit.
- Put your fingers on the metal parts and very slightly, and gently, push them in (do each one, one at a time, and repeat until all four have been adjusted).
- Sometimes these can stick and cause the printer to sense the wrong paper size on the tray.
- Pushing the metal in slightly should reset the parts of the sensor if they are stuck.

Load the check stock back into the paper tray.

- Put the tray back in the printer.
- Turn the printer back on.
- Send a Forms Alignment to see if the paper tray error has resolved.
- If still getting an error, call the NSB Helpdesk.

Looking toward the back left under the printer where the paper tray slides in. These are the 4 metal parts of the paper sensor.

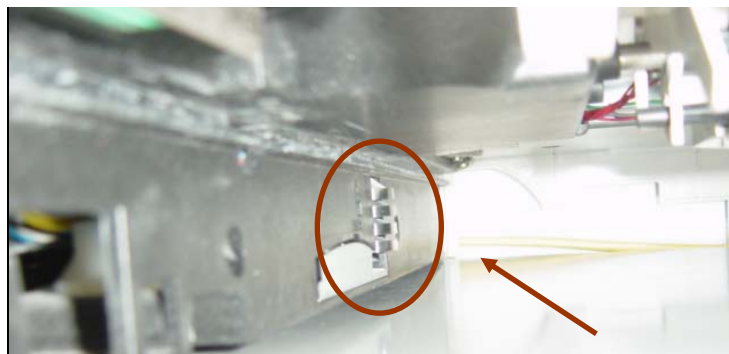

The paper sensor can become damaged or wear out over time. To minimize problems with the paper sensor:

- Do not over-fill the paper tray past the marked line.
- Do not forcefully slam the paper tray shut when closing the paper tray.
- Only use check stock that has been stored on a level surface in large Ziploc bags to lock out moisture. Check stock that is exposed to dampness in the air can thicken imperceptibly, causing the printer to misfeed or jam.

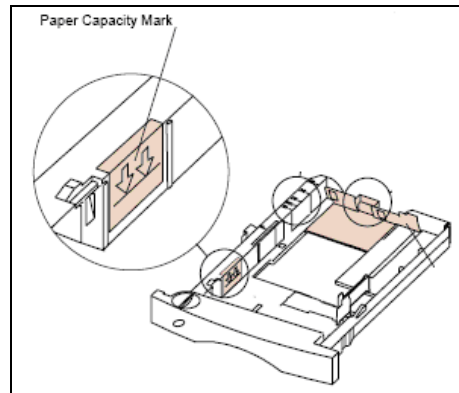

Paper Jams and Damaging the Rollers or Fuser

If there is a paper jam, NEVER stick any objects into the roller area to try to remove jammed paper from inside the printer. Trying to remove paper from the printer this way may cause costly damage to the fuser or inside of the printer. This means:

- NO letter openers
- NO paper clips
- NO scissors
- NO pens
- NO knives
- NO screwdrivers
- **NOTHING**

Only the prepackaged, sealed check stock and receipt paper, from the state authorized check stock vendor should be used in the MICR printers. NEVER substitute any other paper for receipt paper because that might cause paper jams and fuser problems.

When in doubt, call the NSB Helpdesk during normal business hours for assistance.

Password Match Errors

If the MICR printer reports a Password Match Error, prints out incorrect banking information, or prints out garbage characters:

- Remove the check stock from all paper trays and replace it with plain paper.
- Contact the NSB Helpdesk during normal business hours for assistance.
- Tell all WIC users to stop printing food instruments and CVVs to that MICR printer until the problem is resolved.

- If the NSB Helpdesk determines that the printer flash form needs to be updated, make sure the printer remains ON.
- Make sure that a WIC staff person is available to test the printer after the flash form has been updated. Testing is a necessary part of the process for resolving this kind of issue, and may sometimes be time-consuming.

900 Series Service Errors

If the MICR printer reports an error in the 900 series, contact the NSB Helpdesk during normal business hours for assistance.

- Service Error Messages usually indicate printer hardware failures that may require service.
- Some 900 service errors may actually be false messages caused by overheating or inadequate power sources.

Maintain an Acceptable Operating Environment for the MICR Printer

It is important to set up the proper environment for the MICR printer so that it will function at optimal performance. Improper conditions result in unnecessary, excessive and expensive printer repairs or replacements. To set up a proper environment for the MICR printer do the following:

Provide Adequate Space for the MICR Printer

The MICR printer must have adequate space on all sides for proper air flow, to prevent the MICR printer from overheating and becoming damaged.

- There should be 6-12 inches of space around the MICR printer at all times.
- The operating temperature must be between 60 and 90 degrees, and must not exceed 90 degrees.
- Do not stack books, papers, purses, printouts, or anything else near the printer that may impede the air from circulating properly around the printer.
- Do not push the printer all the way against the wall.

Overheating

Overheating due to an improper operating environment can:

- cause false error messages
- damage the fuser
- shorten the life span of the MICR printer
- result in multiple repairs or replacements
- invalidate the warranty and maintenance contract

No Closed-In Spaces

Do not operate MICR printers inside cabinets or drawers.

- There is not adequate clearance for air flow in a closed-in space.
- The operating environment will exceed 90 degrees.



Low Amperage

Plug the MICR Printer into an adequate power supply. Low amperage may occur when the printer is plugged into an old or inadequate power strip. When there is low amperage, the printer may give false error messages.

To remove the error message from the LCD panel:

1. Turn the printer off.
2. Unplug the power cable from the power strip.
3. Plug the power cable into a grounded wall outlet or uninterruptible power supply (UPS).

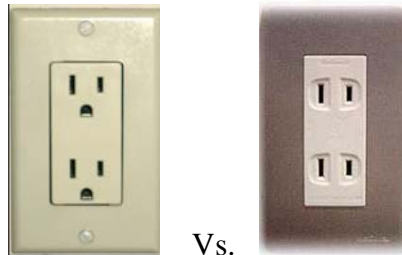

Grounded Outlet **Ungrounded**



UPS – Uninterruptible Power Supply **Basic Power Strip**

Disabled Operator Panel Menus

If the menus are disabled on the MICR printer:

1. Turn the MICR printer off.
2. Press and hold the Select button and the right Navigation button while turning the printer on.
3. Release the buttons when you see a clock.
4. CONFIG MENU appears on the first line of the display.
5. Press the down Navigation button until the checkmark appears next to Panel Menus.
6. Press the Select button.
7. Press the down Navigation button until the checkmark appears next to Enable.
8. Press the Select button.
9. The following messages appear briefly in succession: Submitting selection and Enabling Menus.
10. The operator panel returns to Panel Menus.
11. Press the down Navigation button until the checkmark appears next to Exit Config Menus.
12. Press the Select button.
13. Activating Menu Changes appears. The menus are enabled, and the printer returns to Ready.

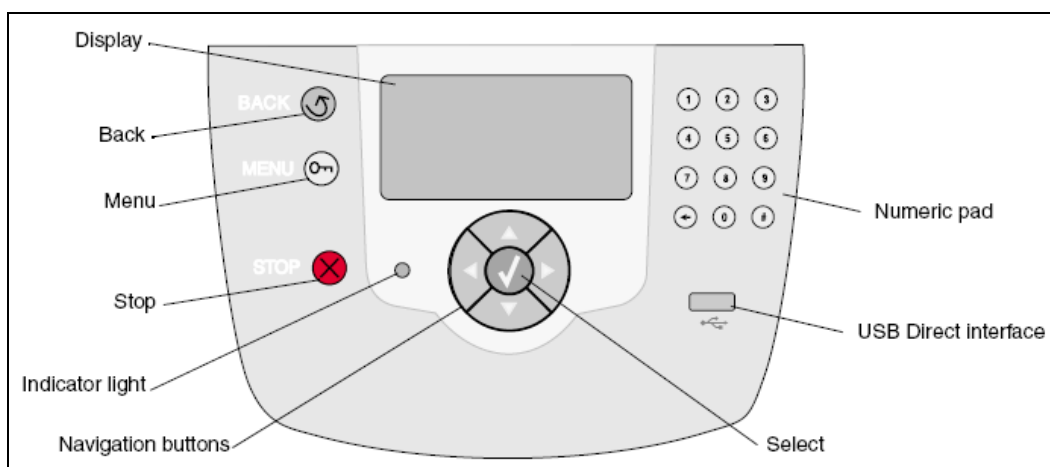

Printing Issues Associated with Screens 21, 53, 55 and 26

If the user is attempting to print food instruments from screens 21 (WIC Issuance), 53 (State Funded Issuance) or 55 (Vendor Voucher Replacement), but nothing printed:

- Go to screen 26 and ensure that the virtual box of food instruments has been assigned to the correct MICR printer node name. When opening a box of virtual voucher numbers, the Printer Node Assigned field for the MICR printer node name is neither highlighted nor underlined, and therefore the MICR printer node name is often forgotten or overlooked on this screen. Refer to Chapter 2 for more information on assigning virtual boxes of food instrument numbers.

Chapter 5: TROUBLESHOOTING
Section 9: PROBLEMS WITH PRINTERS

```
HSA262A 07501 NORTH CAROLINA HSIS - WIC SYSTEM
08/19/09 VOUCHER INVENTORY - PROGRAM/SITE
SCCA
NEXT RECORD: COUNTY: 085 SCREEN: 26 ID: DATE: ACTION: C
MESSAGE: 017 ENTER CHANGES AND THEN PRESS "ENTER"

MAILED: 11/06/01 STATUS: OPEN RECEIVED: 11 / 06 / 01
STATION: 01 ASSIGNED: 11 / 06 / 01 BOX #: 01
BEGINNING NUMBER: 52868001 PRINTER NODE ASSIGNED: -
ENDING NUMBER : 52872000
LAST NUMBER USED: 52871046 LAST USER: H2CI800
NUMBER OF FORMS REMAINING: 00000954
NUMBER OF FORMS USED : 00003046

LOCKOUT CODE: Y LOCKED OUT BY:
```

- If the printer node name in screen 26 is either blank or not correct
 - ▶ Change the Action to the letter C
 - ▶ Type the correct Printer Node name
 - ▶ Press the **ENTER** key.
- Try printing again.
- If the food instruments and CVVs do not print out, turn the printer off, wait a few seconds, and then turn the printer back on.
- If the printer does not start printing food instruments and CVVs, call the NSB Helpdesk.
- Provide the MICR printer node name (Ex. NEMP045E).

Food Instrument Record Number in Use

If attempting to print food instruments and CVVs from screen 21, 53, or 55, and an error message displays Voucher Number Record is in Use:

```
HSA211A                NORTH CAROLINA HSIS - WIC SYSTEM
08/19/09                STANDARD VOUCHER ISSUANCE                SCCA

NEXT RECORD: COUNTY: 041  SCREEN: 21  ID:                DATE:                ACTION: I
MESSAGE: 215 VOUCHER NUMBER RECORD IS IN USE - TRY AGAIN LATER - PF2 FOR MENU

NAME: _____ PGM/SITE: _____ WIC ID: _____
CYCLE: _ DATE: _ LAST DATE ISSUED _____ THRU _____ ACTION DUE: _____ _
NUTRITIONAL EDUCATION: N CODE: _ STAFF: _ DATE: MMDDYY
```

- Check to be sure that no one else in the local agency has logged into HSIS using the same Remote Terminal ID (RTI). For more information on RTIs, refer to Chapter 5, Section 7, Proper Use of the Remote Terminal ID.
- Make sure that no one else is attempting to print food instruments and CVVs from the same FI station (virtual voucher station number).
- Go to screen 26.
- Type the letter X next to “Voucher Inventory” and press the **ENTER** key.
- Under the Last Used Number column, place the cursor directly under the food instrument number of the voucher box (FI station) currently being used.
- Note whether the lockout code is a Y (Yes) or N (No).
- Note the User ID number next to Last User.
- Write down the User ID number next to Locked Out By.
- Call the NSB Helpdesk for assistance.
- Provide the local WIC agency Program and Site Number
- Provide the Remote Terminal ID and FI Station number being used.
- Report the status of the Lockout Code, and mention the User ID numbers for Last User and Locked Out By fields.
- Tell the NSB Helpdesk agent whether or not someone else is using the same RTI or Voucher Station number.
- The NSB Helpdesk agent will unlock the voucher box.
- Go back to screens 21, 53, or 55 and attempt to print food instruments and CVVs.
- Note: It is not necessary to print out a Forms Alignment after the voucher box has been unlocked.
- Let the NSB Helpdesk agent know whether or not the food instruments printed.

Food Instrument Record Number Not Found

If an error message displays Voucher Record Number not Found, the voucher box is either empty (all voucher numbers have been used up), or there are not enough food instrument numbers left in the box to print out the requested amount (ex. there are two voucher numbers left, but the print request is for 3 food instruments and a CVV to be printed).

- Verify how many food instrument numbers are left in the voucher/food instrument box:
- Go to screen 26
- Type the letter X next to Voucher Inventory and press the **ENTER** key.
- Under the Last Used Number column, place the cursor directly under the food instrument number of the voucher box (voucher station) currently being used.

End of Box

If there are no more food instrument numbers left in the virtual Voucher Box:

- If there are only a few food instrument numbers left in the voucher box, clear the box until there are no more food instrument numbers left in that box:
- Go back to the selection menu on screen 26.
- Type the letter X next to Voucher Forms Alignment and press the **ENTER** key.
- Repeat the forms alignment until all food instrument numbers in the virtual box have been used.
- Go back into Voucher Inventory and verify that the Ending Number matches the Last Number Used.

HSA262C 07501 NORTH CAROLINA HSIS - WIC SYSTEM							
02/03/05 VOUCHER INVENTORY - PROGRAM/SITE							
NEXT RECORD: COUNTY 085 SCREEN 26 ID DATE ACTION							
MESSAGE: 119 LAST PAGE DISPLAYED, PRESS PF7 TO PAGE BACKWARD							
USING ARROW KEYS, POSITION CURSOR ON ID LINE - "ENTER" TO SELECT							
DATE	STATION	BEGINNING NUMBER	ENDING NUMBER	LAST NUMBER USED	RCVD	ASSIGNED	BOX #
02/07/03		59016000	59017000	*****	Y	Y	17
02/07/03	17	59016000	59017000	59016282	Y	Y	17
08/14/03		75622001	75626000	*****	Y	Y	40
08/14/03	01	75622001	75626000	75622232	Y	Y	40
08/14/03		75626001	75630000	*****	Y	Y	41
08/14/03	75	75626001	75630000	00000000	Y	Y	41
06/10/04		78190451	78190500	*****	Y	Y	64
06/10/04	36	78190451	78190500	78190469	Y	Y	64
02/25/04		78190801	78190850	*****	Y	Y	36
02/25/04	23	78190801	78190850	78190850	Y	Y	36
02/25/04		78190851	78190900	*****	N	N	35

- ▶ When the voucher/food instrument box is empty, open a new box of food instrument numbers:
 - Type the letter X next to Voucher Inventory, and change the Action code to the letter C.
 - Look for a voucher/food instrument box that has not yet been opened.
 - Note: If there are no unopened voucher/food instrument boxes at the bottom of the voucher/food instrument inventory list press <F7> to page back to the top of the voucher/food instrument inventory list and assign a new virtual box of food instrument numbers to the MICR printer node name.

Reprinting of Food Instruments Due to Paper Running Out

The MICR printer will beep when the check stock paper supply is very low. To prevent the MICR printer from running out of paper stock, check the paper supply in the early afternoon or periodically throughout the day to replenish stock. Immediately invalidate any duplicate issuance of food instruments to one participant that may have been printed after the check stock

has been replenished.

Printer Prints Food Instruments and CVVs but Not Receipts

- If the printer prints food instruments and CVVs but no receipts print, staff should:
 - ▶ use a blank food instrument receipt stub and fill in the following information:
 - Program,
 - Site,
 - Date Printed,
 - User ID,
 - Participant ID,
 - Participant Name (Last, First, MI),
 - Issue Date,
 - Beginning & Ending Number of the Food Instruments,
 - Total number of Food Instruments Issued,
 - Beginning & Ending Number of the CVVs, and
 - Total number of CVVs Issued.
 - ▶ Have the participant sign and date the receipt.
 - ▶ Store the written receipt with other receipts from the day.

Printer Prints Duplicate Numbers

A printer may print duplicate numbers for a variety of reasons. If this occurs, duplicate food instrument and CVV numbers must be voided in HSIS. If the problem continues to happen, call the NSB Helpdesk. Reasons duplicate numbers might occur include the following situations:

- A staff person printing food instruments and CVVs may accidentally press the **ENTER** key twice so that the food instruments and CVVs print twice for the same person.
- There is an interruption of power (i.e. power outage) while food instruments and CVVs are printing. If you think this situation has occurred, check the power cord for the printer to make sure it is secure at both ends. Then check the cable that goes from the PC or network outlet to the printer to make sure it is secure.
- If a user has logged into HSIS using someone else's Remote Terminal ID number by mistake, and they contact the NSB Helpdesk to unlock that voucher station before checking that someone else is also using the same Remote Terminal ID number at the same time, duplicate food instrument and CVV numbers can be printed.

Problems Printing Labels

When printing address labels from HSIS, if the addresses do not line up correctly on your label sheets, try the following settings for the report printer queue in RPM, using Print Text setup:

Avery 1 1/3" x 4" (# 5961) - 2 across, 10 down for a total of 20 labels:

- Font - Courier New, Regular, 12 (size)
- Margins: Top = .625 , Bottom = .375, Left and Right = 0
- Use Lines per inch = 6
- User Char per inch = 9.5
- Check only the option "Never Print the banner page"
- All other options should not be checked.

Avery 1" x 4" (#5162) - 2 across, 7 down for a total of 14 labels:

- Font - Courier New, Regular, 12 (size)
- Margins: Top = .9 , Bottom = .1, Left and Right = 0
- Use Lines per inch = 4.51
- User Char per inch = 9
- Check only the option "Never Print the banner page"
- All other options should not be checked.

Avery 1" X 2.63" (5160 or 8930) - 3 across, 10 down for a total of 30 labels:

- Font - Courier New, Regular, 12 (size)
- Margins: Top = .625 , Bottom = .375, Left and Right = 0
- Use Lines per inch = 6
- User Char per inch = 9.5
- Check only the option "Never Print the banner page"
- All other options should not be checked.